

Ultrasonic distance and proximity sensors UPK Series

- Measuring distances from 80mm up to >5m
- High detection sensitivity
- Very low profile, small size
- Versions with analogue and/or binary output
- Versions with synchronisation input
- Measurement independent of material, surface, colour and size of target
- Work under dust, dirt, fog, light
- Detect transparent and bright objects
- Watertight, IP 67, oil resistant, robust
- M8 connector for screw or snap-on
- Versions with shielded integrated cable
- Customized versions available
- Swiss made



download data sheet on
your smart phone with
a QR-Code scanner app.

the flattest!

Technical specifications

		UPK 500	UPK 1000	UPK 2500	UPK 5000
Detection range nominal, with standard versions	mm	80...500	135...1000	250...2500	400...5000
Detection range POR-Version for bigger objects	mm	80...~800	135...~1500	250...>3000	400...>6500
Blind range (no reasonable analogue signal)	mm	0...80	0...135	0...250	0...400
Adjustment range of binary output (with potentiometer)	mm	80...500	135...1000	250...2500	400...5000
Hysteresis of binary output, axial, @ FS _{nom.}	mm	~15	~25	~40	~80
Resolution	%FS	~0.2%	~0.1%	~0.1%	~0.1%
Linearity	%FS			<±0.5%	
Temperature error -20...+50°C	%			<1	
Over all accuracy in whole temperature range	%FS			~±1	
Operating frequency	kHz	~180	~180	~120	~80
Status indicator	-			LED red/green	
Binary output, short circuit proof, max. 0.1A	-			by choice PNP, NPN, NO, NC	
Switching speed max.	Hz	~8	~5	~3	~2
t _{on} / t _{off} (binary output @ 50%FS, without background)	ms	~50 / 80	~130 / 90	~200 / 120	~700 / 140
Analogue output in detection range (Versions)					
R _L min. 10kΩ with V output	V		(0)...10 or (10)...0V		
R _L max. 400Ω with mA output	mA		(4)...20mA or (20)...4mA		
Ripple of analogue output @ FS _{nom.}	mV	~±60	~±20	~±15	~±20
Tracking speed of analogue output	s/95%FS	0.06	0.25	0.4	<2
Power supply voltage (reversal polarity protection)	VDC			15...30	
Ripple of supply voltage	%			<10	
Mean consumption, switched without load	mA	~60	~60	~60	~65
Peak current, switched without load	mA	~85/0.1ms	~85/0.1ms	~95/0.2ms	~100/0.3ms
Temperature coefficient of air path	%/°K				-0.17 (increasing temperature → output decreases)
Ambient temperature during operation	°C			0...+50	
Sensor temperature during operation	°C			0...+70	
Pressure range	mbar _{abs}			~900...1100	

www.sntag.ch

This Information corresponds to the current state of knowledge. SNT reserves the right to make technical changes. Do not use these products in any application where failure of the product could result in personal injury. Liability for consequential damage resulting from the use of SNT products is excluded.

SNT Sensortechnik AG, Hammerstrasse 6, CH-8180 Bülach, Switzerland, Phone +41 44 817 29 22, Fax +41 44 817 10 83, info@sntag.ch

Technical specifications (continued)

		UPK 500	UPK 1000	UPK 2500	UPK 5000
Mass without cable	g	~90	~90	~90	~105
Protection class	-			IP67	
Housing material	-			Polyamide glass-fibre reinforced	
Electrical connection	-			M8 connector 4-pin or integrated cable	

High power density

The outstanding feature of the UPK series is its high acoustic power combined with small sensor size. This is achieved with new optimized **SONARANGE** transducers, working at high electrical voltages. Thus also small, moving and poorly reflecting objects can be safely detected. Moreover the sensors work also under high contamination. With a length of <40mm the UPK sensors are the most compact ultrasonic sensors for such high measuring ranges.

Thanks to the new transducer sealing made of Viton® the UPK sensors are very robust against many environmental influences. In particular, they are oil resistant, unlike many other ultrasonic sensors.

AGC (Automatic Gain Control)

AGC is exclusively used in the UPK series. It adjusts automatically the detection sensitivity to the reflected signal intensity, allowing the detection of very small objects.

Temperature compensation

The temperature coefficients of the electronics and the transducer are compensated thanks to a special circuit.

Choice of model

The UPK versions differ particularly by their different measuring ranges. The following versions are available for each measuring range:

- Fixed analogue output and 1 adjustable binary output
- 2 individually adjustable binary outputs
- Analogue output with adjustable zero and FS

The analogue outputs are available with 0...10V or 4...20mA and furthermore with inverted analogue outputs 10...0V or 20...4mA. Other versions are available on demand.

Binary outputs

Binary outputs become active, i.e. they switch on or off, when a scanned object falls below the set distance or if it exceeds it. Each switch point has a hysteresis (see technical specifications). This is the difference between the switch on and switch off point during approach or departure. Hysteresis is necessary for an appropriate switching behaviour.

Synchronisation input (Y versions)

The ultrasonic signals can disturb each other when several sensors are focused on the same target or when sensors are mounted too close together. This can be avoided by synchronizing the sending pulses. The synchronisation leads if all sensors are connected to each other by shielded cables as short as possible. Since all sensors send then simultaneously, the current consumption increases heavily. Unused synchronisation leads shall be isolated.

Blind range

The lower detection range is called blind range. It is typical for ultrasonic sensors. In the blind range no distance measurement is possible however the pure function as a proximity switch (binary output) is possible in the blind range with certain restrictions (only bigger objects).

Inclination angle of object

Smooth surfaces can be detected up to an inclination angle of 10°. However rough and structured (granular) surfaces can be detected up to much higher angles.

Cable

All standard versions have a 4-pin M8 connector for screw or snap-on connection. The Y-versions with synchronisation input have a shielded integrated cable (l=2m). Special cable lengths and integrated cables instead of connectors are available on demand. The cable should be kept as short as possible. Maximum cable length is approx. 100m, if cross section area is appropriate (peak current <100mA, use 470µF/35V backup capacitor close to sensor). The cable should not be mounted parallel or close to high current cables.

Cables for connection to the M8 connector have to be ordered separately.

Mounting

The UPK sensors have 4 threaded holes on their rear side of the housing. They can be mounted with M4 screws. 4x M4x20 screws are provided with each sensor. The UPK 5000 versions shall be mounted with the damping rubber bush (included) in order to avoid acoustic cross talk. An optional mounting bracket Type UPM made of glass fibre reinforced plastic can be ordered.

Power supply

Ideally a power supply is used exclusively for the sensor. The power supply must be able to supply the short peak current of 80...100mA for each sensor. In order to avoid disturbances the part where the sensor is mounted must be correctly earthed.

Detection beams

The detection beam of an ultrasonic sensor generally has the shape of a cone. The size depends on the target and its sound reflecting characteristics. Small and less reflective objects result in a smaller cone (narrower and shorter).

Larger objects and those with surfaces which are not perpendicular to the central axis can expand the cone. The exact cone shape and size can be determined only at the object itself. No disturbing objects must be between the sensor and the target within the cone. Otherwise the sensor would detect the disturbing object instead of the desired target. Below are some typical cone shapes for each sensor type. The solid line shows the range, where the sensor detects flat objects of size A4 (UPK 500/1000) or A3 (UPK 2500/5000) which are perpendicular to the sensor axis. In the dotted range the sensor UPK 500/1000 detects round objects (Ø10mm). For UPK 2500/5000 the dotted range is the area where the sensor detects only large and very well reflecting objects. Furthermore the size of the detection beam is influenced by air temperature and humidity. The colder and dryer the air, the larger is the beam. **The extended measuring range (above nominal range) is only available with the POR versions.**

No other ultrasonic sensor working at the same frequency should be within the sensing cone, close to it or opposite to it. This is only allowed when using the synchronisation option (Y-versions).

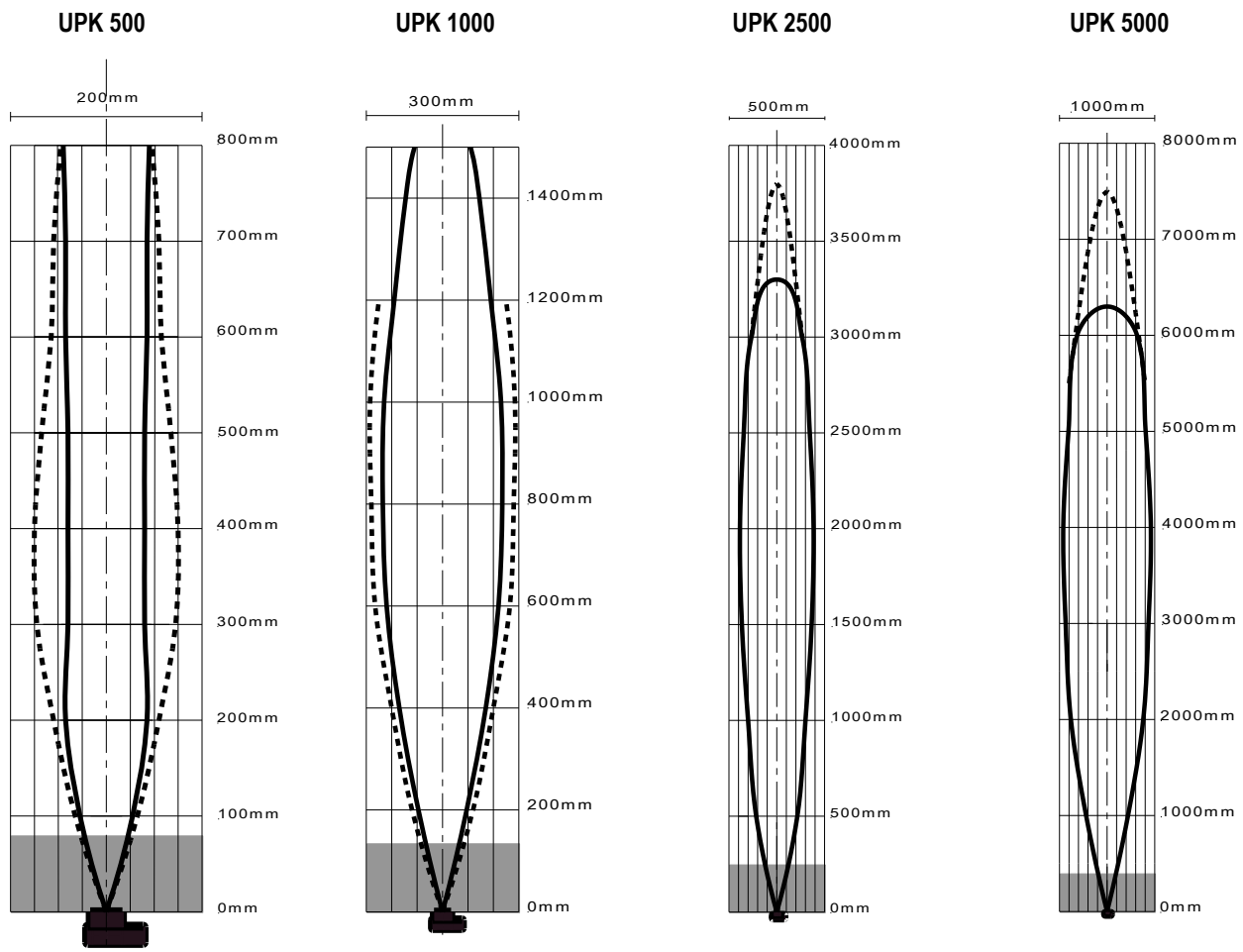

Settings

Binary outputs:

The switching distance is set with a 4-turn potentiometer. An object with reasonable size and perpendicular to the sensor axis is placed at the desired distance from the sensor. First the potentiometer is turned min. 4x counter clockwise to zero (no stop). Then the potentiometer is slowly turned clockwise until the LED illuminates (NO) or expires (NC). Thus, the switching distance for the binary output is set. Red corresponds to the output 1 (NO or NC) and green to the output 2 (always NO). The versions with two binary outputs have a bi-coloured LED (red/green).

Adjustable analogue outputs:

Near and far end points of the analogue outputs can be set on the POR versions with two 4-turn potentiometers. The analogue output has to be monitored with a multi-meter.

Near endpoint:

The near endpoint is at the position of the sensor diaphragm when potentiometer No. 1 is turned at least 4x counter clockwise (no stop). If near point shall be in some distance from the sensor, one has to place there an object with reasonable size. The potentiometer is turned min. 4x clockwise (no stop). Then slowly turn counter clockwise until the reading starts to increase (>0V or 4mA). On inverted versions ("V") where it starts to decrease (<10V or 20mA).

Far endpoint:

An object with reasonable size is placed at the desired distance. With potentiometer No. 2 the desired reading (10V or 20mA) is then set. On inverted versions "V" 0V or 4mA.

The near endpoint and the gain can be varied within certain limits (see table below). However, in the range >100% the sensor will detect only large objects and above a certain distance no objects at all. If at near endpoint a higher value shall be shown than at far endpoint, then the inverted version 'V' must be used.

Type	near endpoint normal: 0V/4mA inverted: 10V/20mA		Gain [mm per 10V or 20mA]	
	Min. [mm]	Max. [mm]	Max.	Min.
UPK 500	0	300	100	800
UPK 1000	0	500	200	1500
UPK 2500	0	1500	500	3800
UPK 5000	0	3000	1000	8000

Use the miniature screw driver (included) for adjustment of the potentiometers.

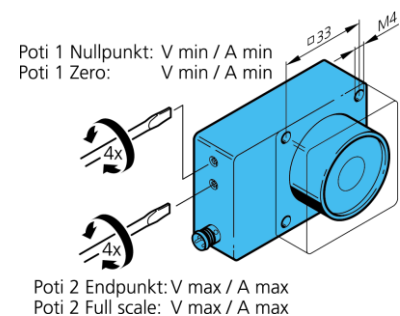
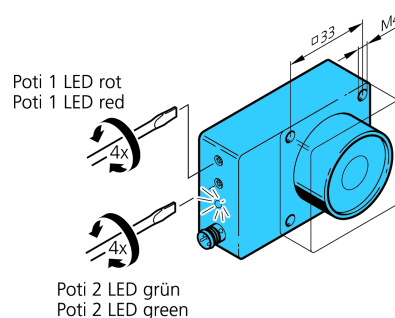
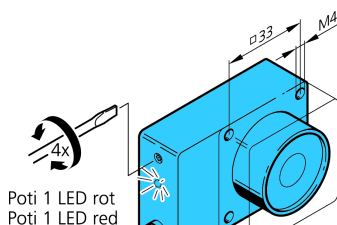

Type

UPK xxxx PVPS 24 CA
UPK xxxx PVPS 24 CI
UPK xxxx PVPS 24 CVA
UPK xxxx PVPS 24 CVI

UPK xxxx PDPS 24 C
UPK xxxx PDPA 24 C

UPK xxxx POR 24 CAI
UPK xxxx POR 24 CVAI

Outputs

1 binary output, 1 analogue output

2 binary outputs

2 analogue outputs (V und mA)

Setting elements

1 potentiometer, 1 LED

2 potentiometers, 1 bi-colour LED

2 potentiometers, no LED

Dimensions

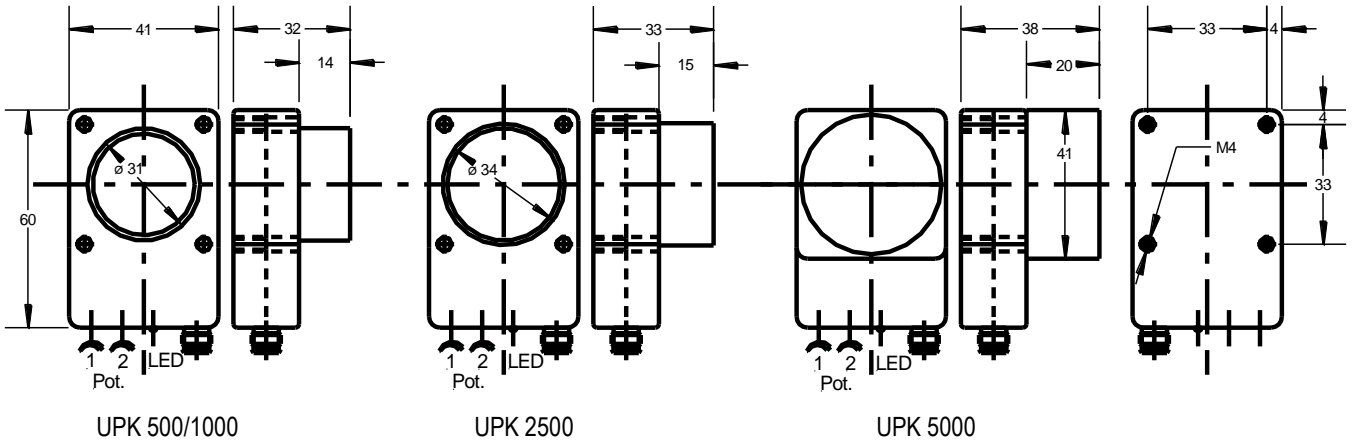

Standard versions

1 analogue output + 1 binary output		Schema
UPK XXXX PVPS 24 CA	1 binary output, PNP NO, 1 analogue output 0...10V, 4-pin connector, 1 pot., 1 LED	A
UPK XXXX PVPS 24 CI	1 binary output, PNP NO, 1 analogue output 4...20mA, 4-pin connector, 1 pot., 1 LED	A
UPK XXXX PVPS 24 CVA	1 binary output, PNP NO, 1 analogue output 10...0V, 4-pin connector, 1 pot., 1 LED	A
UPK XXXX PVPS 24 CVI	1 binary output, PNP NO, 1 analogue output 20...4mA, 4-pin connector, 1 pot., 1 LED	A
2 binary outputs		
UPK XXXX PDPS 24 C	2 binary outputs, PNP NO, 4-pin connector, 2 pot., 1 bi-colour LED	B
UPK XXXX PDPA 24 C	1 binary output, PNP NO, 1 binary output, PNP NC, 4-pin connector, 2 pot., 1 bi-colour LED	B
2 analogue outputs		
UPK XXXX POR 24 CAI	1 analogue output 0...10V, 1 analogue output 4...20mA, zero and FS adjustable, 4-pin connector, 2 pot., no LED	C
UPK XXXX POR 24 CVAI	1 analogue output 10...0V, 1 analogue output 20...4mA, zero and FS adjustable, 4-pin connector, 2 pot., no LED	C
Option synchronisation input		
All versions UPK Y	additionally synchronisation input, integrated shielded cable 2m	D

Nearly all possible versions are available according to the following product key.

Nominal detection range: XXXX: 500 = 500mm, XXXX: 1000 = 1000mm, XXXX: 2500 = 2500mm, XXXX: 5000 = 5000mm

UPK XXXX P □ □ □ 24 □ □ □ □

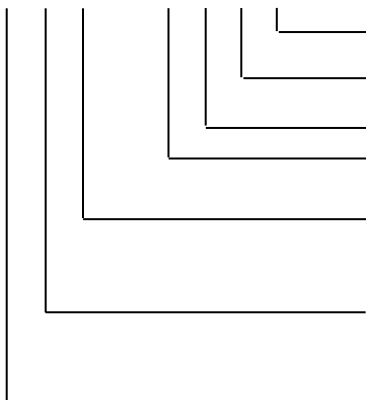

Synchronisation input	Y
Analogue output 10V	A
Analogue output 20mA	I
Inverted analogue output	V
M8 connector (else cable)	C
Binary output NO	S
Binary output NC	O
Binary outputs NO+NC	A
Binary output PNP	P
Binary output NPN	N
Analogue output with adjustable FS	R
1 Binary output	V
2 Binary outputs	D
Analogue output with adjustable zero	O

Diagrams of connections

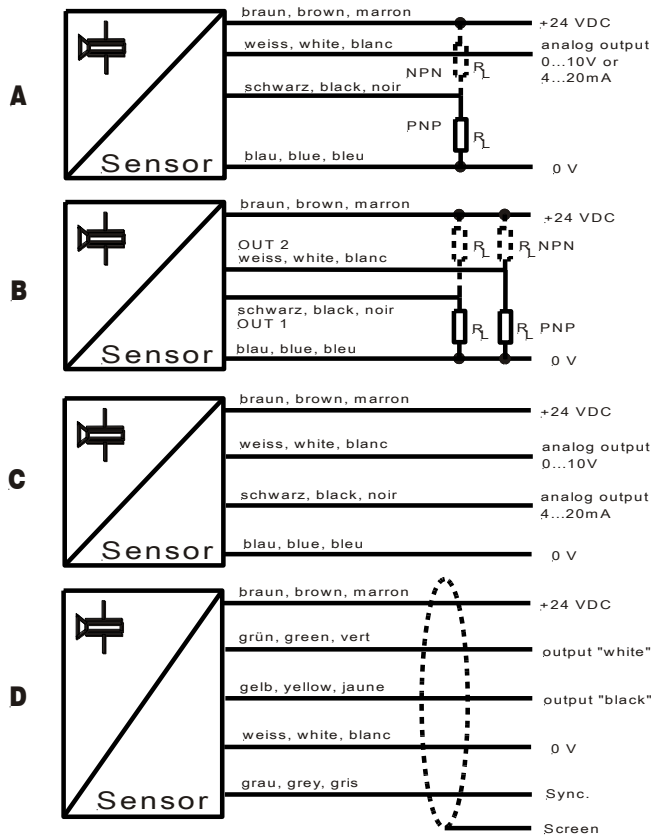

All versions with integrated cable instead of connector have cable colours according to scheme "D".

4-pin connector

- | | |
|---------|---------|
| 1 brown | 3 blue |
| 2 white | 4 black |

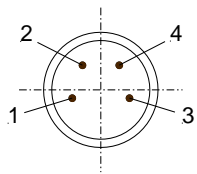

View on the sensor

Parts included

- Sensor
- 4 screws M4x20mm for mounting
- UPK 5000: damping rubber for mounting
- Miniature screw driver for potentiometer

Some typical ultrasound applications

Level measurement

- Measuring level in small containers
- Water gauge measurement
- Monitoring liquid levels in bottling plants
- Checking for tailbacks on conveyor belts
- Monitoring contents of granular hoppers on injection moulding machines
- Distance monitoring on combine harvesters, beet lifters etc.
- Monitoring ground clearance and distance on agriculture and construction vehicles

Process control

- Controlling belt tension or sag
- Sensing and signalling valve positions
- Measuring roll diameter on reeling machines
- Monitoring the height of stacks (pallets, storehouse, assembling machines)
- Detecting material feed
- Detecting the feed of strip stock to blanking machines and presses
- Detecting on plastic blow-moulding machines

Counting / Detection

- Counting onlookers at freestanding sales displays or show cases
- Access supervision at rotating doors, counters etc.
- Door and lift automation
- Detecting transparent objects, foils, flat glass, bottles etc.
- Sensing objects in robot grippers
- Recognizing full or empty pallets
- Count and detect objects with 'difficult' surface
- Detect wrong parts on conveyors
- Collision protection on vehicles

Scanning of dimensions

- Determining the dimensions of packages
- Sensing the height of plants in automated green houses
- Measuring the volume of tree-trunks

Accessories (see also data sheet ,ACC')

Cables 4-pin with M8 screw connector, PUR:

With straight connector: l=2m Type KAB 2K4VGPUR
l=5m Type KAB 5K4VGPUR

With 90° connector: l=2m Type KAB 2K4VWPUR
l=5m Type KAB 5K4VWPUR

Mounting bracket made of reinforced polyamide:

Type UPM